

RESISTANT MATERIALS QUESTIONS

V.Ryan © 2000 - 2009

On behalf of The World Association of Technology Teachers

W.A.T.T.



World Association of Technology Teachers

This exercise can be printed and used by teachers and students. It is recommended that you view the website (www.technologystudent.com) before attempting the design sheet .

THESE MATERIALS CAN BE PRINTED AND USED BY TEACHERS AND STUDENTS.
THEY MUST NOT BE EDITED IN ANY WAY OR PLACED ON ANY OTHER MEDIA INCLUDING WEB SITES AND INTRANETS.
NOT FOR COMMERCIAL USE.
THIS WORK IS PROTECTED BY COPYRIGHT LAW.
IT IS ILLEGAL TO DISPLAY THIS WORK ON ANY WEBSITE/MEDIA STORAGE OTHER THAN www.technologystudent.com

PRODUCT ANALYSIS - EXERCISE

V.Ryan © 2009 World Association of Technology Teachers



The desk organiser seen opposite is basically a plastic insert that fits inside a desk drawer. It is like a tray and can be left in the drawer and the drawer can be locked. Alternatively, it can be removed and placed on the top of the desk as it lies flat against the level table/desk surface.

You are to carry out a product analysis of the desk organiser. Write a sentence or more alongside the prompts. There is space for your own individual remarks about the desk organiser.

WHAT PRODUCT ANALYSIS TELLS US ABOUT THE DESK ORGANISER

1. Material: _____
2. Weight: _____
3. Strength and resistance to knocks: _____
4. Colour: _____
5. Equipment it is likely to store _____
6. Stability / balance: _____
7. Safety: _____
8. Manufacturing processes: _____
9. Overall size: _____
10. Efficient use of space / inefficient use of space. _____
11. Position of writing pad: _____
12. _____
13. _____

DESIGN / PRODUCT IMPROVEMENTS

Now that you have carried out your own product analysis, describe a few design improvements.

THE DESIGN SPECIFICATION

V.Ryan © 2009 World Association of Technology Teachers

Having asked all the important questions, the designer can now write a design specification. The specification is a list of factors that the design must satisfy. This information can be used when drawing ideas, to ensure that all the clients needs are considered. The designers specification is seen below.

1. The desk organiser will store the following equipment;
Pens, pencils, ruler, scissors, glue, paper clips, compass, protractor, calculator, stapler, mobile phone etc....
2. The overall size of the organiser will be 200 X 250 X 200mm
3. The organiser will not be lockable and will be placed on the table / desk top.
4. The organiser will help the client complete tasks such as writing, drawing, stapling, drinking coffee, reading and calculating sums.
5. It will be designed for the clients specific needs.
7. It will cost between five and six pounds to manufacture.

At this point other points may be added such as;

8. It will be safe to use as it will not have sharp edges. It will satisfy British and European safety standards.
9. It will be made from recycled material.
10. It will be light but very strong.
11. It will be manufactured in a range of colours.

Can you think of any more points that need adding to the specification ? List them below.

Write the design specification for two of the following pieces of desk/table top equipment.

MOBILE PHONE PAPER WEIGHT READING LIGHT LETTER RACK

List desk/table top equipment / stationery that has been missed so far, that you consider important to the office worker.

EXAMINATION QUESTION

V.Ryan © 2009 World Association of Technology Teachers



The two desk organisers opposite are commonly found on office desks.

1. Name two materials that could be used to manufacture either of the sample organisers

MATERIAL ONE: _____ MATERIALS TWO: _____

2. Choose one of the materials you named in question 1. One property your material must possess is described below

PROPERTY: TOUGHNESS WHY: The material must be tough so that it can withstand knocks and blows. If it is knocked off the table it must not break or shatter.

Describe three more properties that the material must have and why the properties are important.

A. Property 1: _____ WHY: _____
B. Property 2: _____ WHY: _____
C. Property 3: _____ WHY: _____

3. Many items such as scissors, paper clips, pens and pencils will be stored in the organiser. Describe how you would determine what people want to store in their desk organisers.

4. If a thousand desk organisers are to be manufactured, this is called BATCH manufacturing.

4a. If only one desk organiser is to be manufactured , this is called _____

4a. If the desk organiser is to be manufactured twenty four hours a day and 365 days a year, this is called _____

EXAMINATION QUESTION

V.Ryan © 2009 World Association of Technology Teachers

PRODUCT 'A'

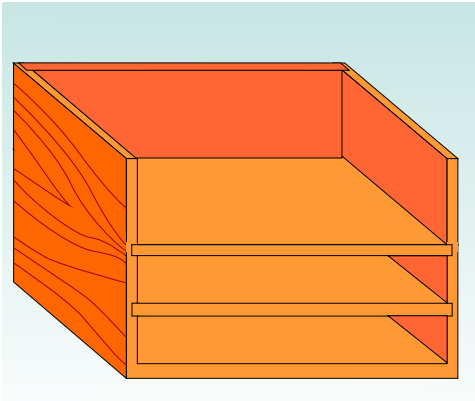

The products shown to the right and left are desk organisers. They are both designed to hold paper / card and to store other items such as pens, pencils, rulers, compasses, computer disks and the usual equipment and items used in an office.

PRODUCT 'B'



1. In your opinion, which product - 'A' or 'B' is the most suitable as a desk organiser ? Explain your answer.

Which is the most suitable product? _____

Why is it the most suitable? _____

2. Name a wood that could be used to manufacture product 'A'.

Name of wood: _____

Why have you chosen the material named above?

2. Name a material that could be used to manufacture product 'B'.

Material Name: _____

Why have you chosen the material named above?

EXAMINATION QUESTION

V.Ryan © 2009 World Association of Technology Teachers

TRADITIONAL DESK ORGANISER

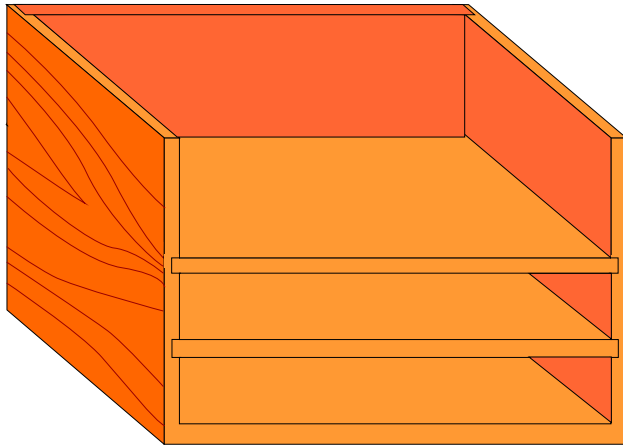

1. The diagram opposite shows a typical traditional desk organiser, designed to hold stationery equipment.
Name five items of stationery equipment you would choose to store in / on this an organiser.

- ITEM 1: _____
- ITEM 2: _____
- ITEM 3: _____
- ITEM 4: _____
- ITEM 5: _____

2. The desk organiser shown above could be improved. On the basic diagram shown below, draw three improvements / additions you could make to the design, without changing the design completely. Include notes to explain your changes / additions.

NOTES

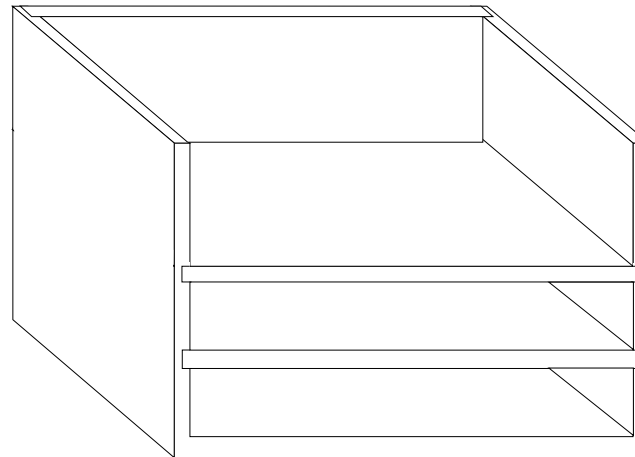

NOTES

EXAMINATION QUESTION

V.Ryan © 2009 World Association of Technology Teachers

TRADITIONAL DESK ORGANISER

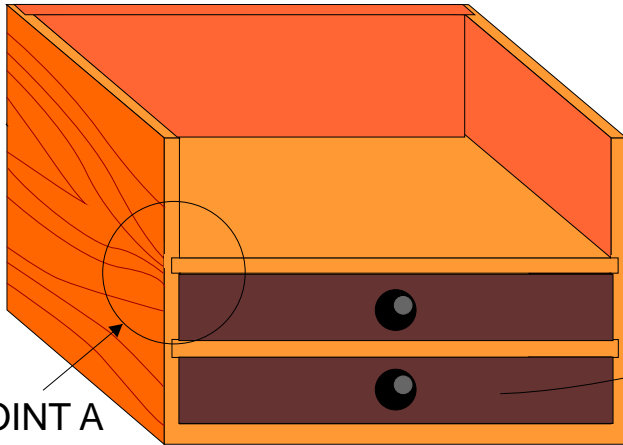

JOINT A

The diagram opposite shows a typical traditional desk organiser, designed to hold stationery equipment. It has two drawers with handles.

1. On the side view of one of the drawers (below), draw the joints you would use at the back corners.

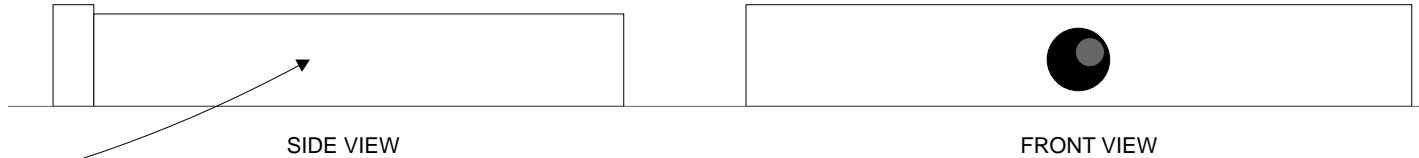

2. Name your chosen joint: _____

3. Explain your choice of joint. _____

4a. Joint 'A' is highlighted on the drawing above. This joint holds the shelf permanently in position.

Name the joint: _____

4b. Why has this joint been used?

4c. In the space below, draw a detailed diagram of the joint. Add notes / labels.

EXAMINATION QUESTION



The product shown to the left is a modern desk organiser. It has several compartments designed to hold different pieces / types of stationery. It is made in one piece, there are no joints.

1. Name a suitable material: _____

2. Describe four properties the material possesses and why each property is important for the product.

PROPERTY 1: _____

PROPERTY 2: _____

WHY IMPORTANT: _____

WHY IMPORTANT: _____

PROPERTY 3: _____

PROPERTY 4: _____

WHY IMPORTANT: _____

WHY IMPORTANT: _____

3. Opposite is a piece of machinery that is used to manufacture the desk organiser. Name the machine, label the parts and describe the process of manufacture.

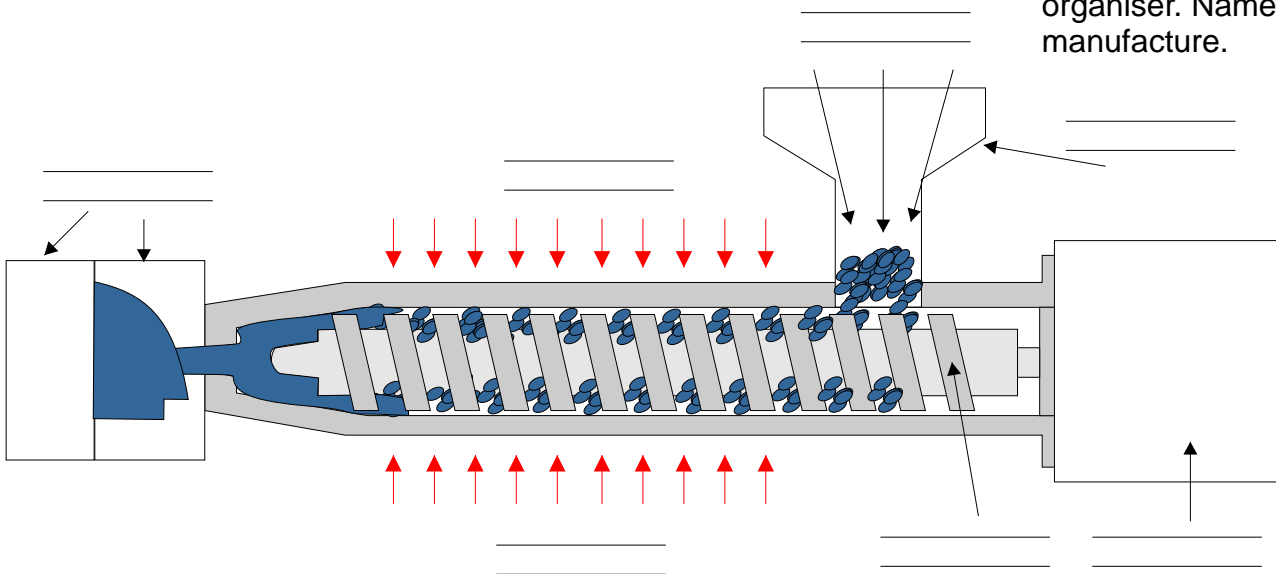

MACHINE NAME: _____

PROCESS DESCRIPTION: _____

EXAMINATION QUESTION

V.Ryan © 2009 World Association of Technology Teachers

Below is a typical desk organiser. In the space provided name the equipment that would be most suitably stored in the areas identified by arrows A, B, C, D, and E.

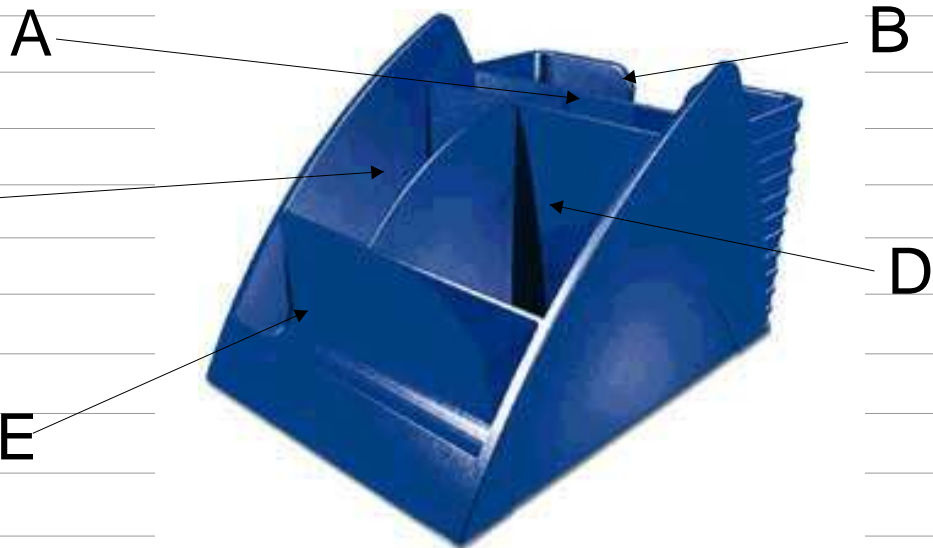

DIAGRAM 'A'



DIAGRAM 'A'

Diagram 'A' is a typical desk organiser. It is made from high density polystyrene and has been manufactured through injection moulding. Diagram 'B' is a mobile phone holder for a car. It is also made by injection moulding using the same material. On a separate sheet, design a desk organiser that can also hold / store a mobile phone. You may wish to consider combining the two sample designs.

EXAMINATION QUESTION

V.Ryan © 2009 World Association of Technology Teachers

The photograph (DIA 1) shows a desk organiser made from high density polystyrene. DIA 2 shows a roll of Sellotape. A survey has shown that potential clients feel that a Sellotape holder and cutter should be added to update the organiser. On both the three dimensional drawing AND the orthographic drawings add a design for the Sellotape holder and its cutter. marks will be awarded for accuracy of drawing and the use of colour and shade.

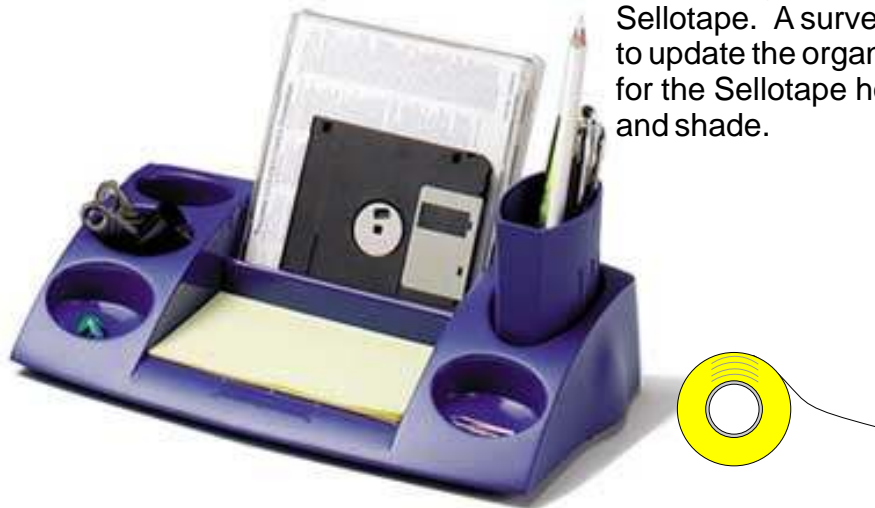

DIA 1

DIA 2

THREE DIMENSIONAL DRAWING

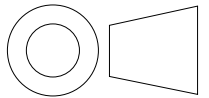
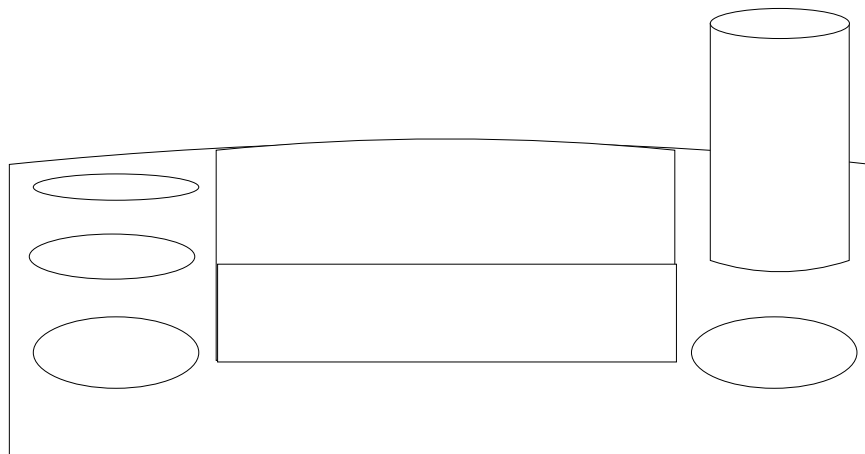
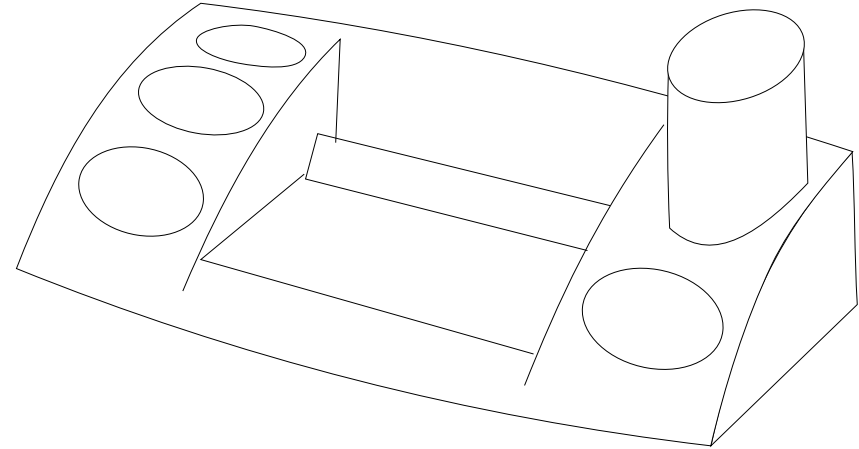

THIRD ANGLE PROJECTION

EXAMINATION QUESTION

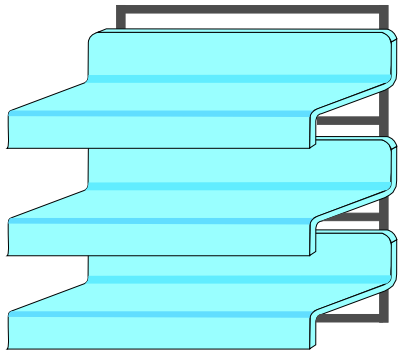

The desk organiser seen on the left is composed of plastic shelves and a metal frame. The diagram on the right shows that the shelves can be removed from the frame and stacked separately.

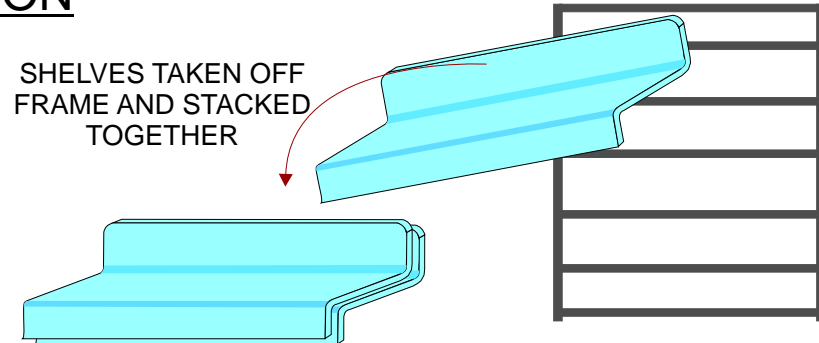

1. Name a suitable metal for the frame

2. Name a suitable plastic for the shelves _____

3. Is your chosen plastic a THERMOSETTING or THERMOPLASTIC

4. Describe a property of a THERMOSETTING plastic.

5. Describe a property of a THERMOPLASTIC.

6. In the four boxes below draw diagrams to represent stages of forming one of the shelves. Add labels and notes

<p>1.</p> <p>_____</p> <p>_____</p> <p>_____</p>	<p>2.</p> <p>_____</p> <p>_____</p> <p>_____</p>	<p>3.</p> <p>_____</p> <p>_____</p> <p>_____</p>	<p>4.</p> <p>_____</p> <p>_____</p> <p>_____</p>
--	--	--	--

4. The main plastic body of the sellotape dispenser / cutter is seen opposite. An incomplete orthographic drawing of the main body is also shown below (drawn in Third Angle Orthographic Projection).

- A. Complete the orthographic drawing
- B. Add hidden detail.
- C. Add the correct symbol representing Third Angle Orthographic Projection.
- D. Add six correctly drawn dimensions.

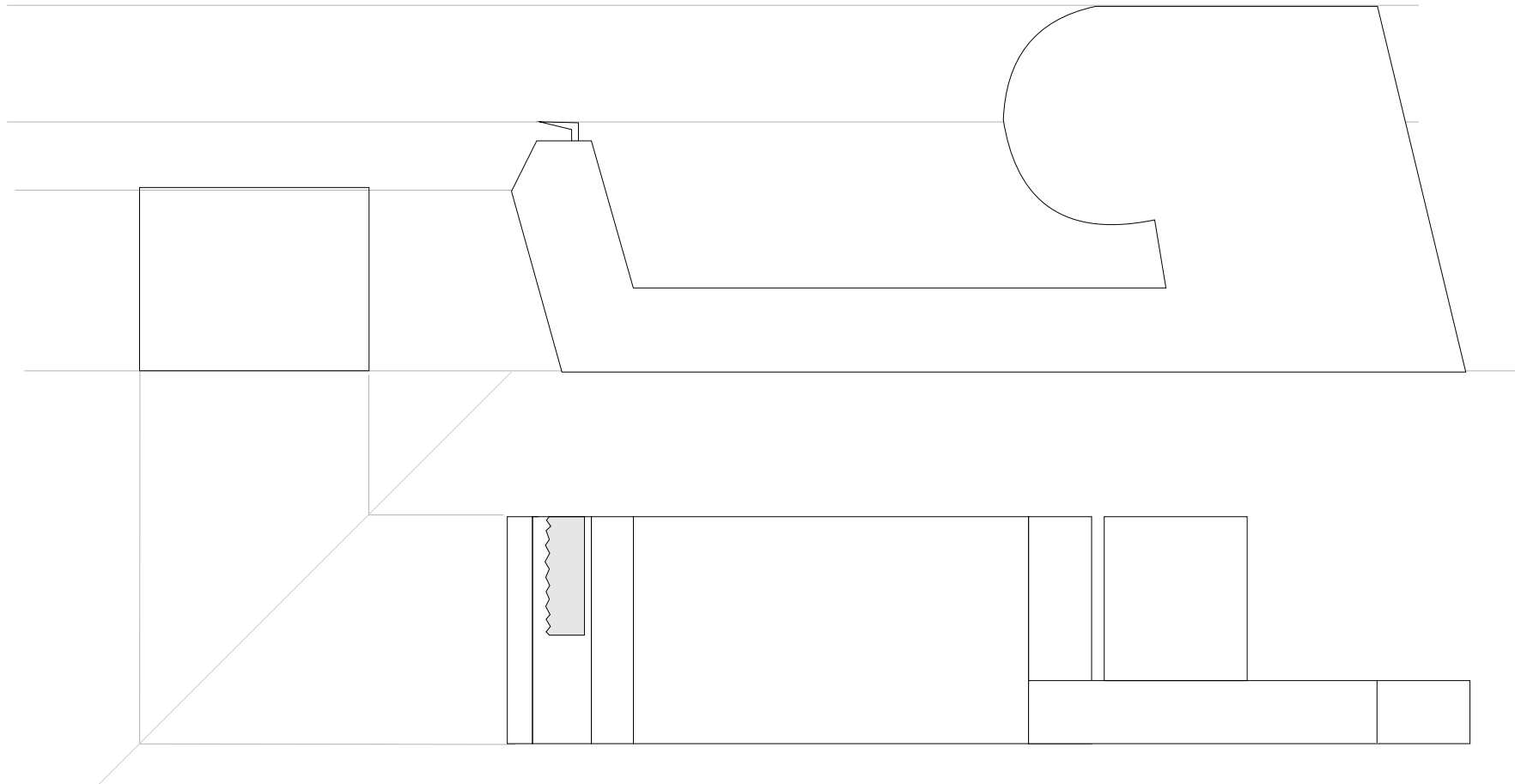
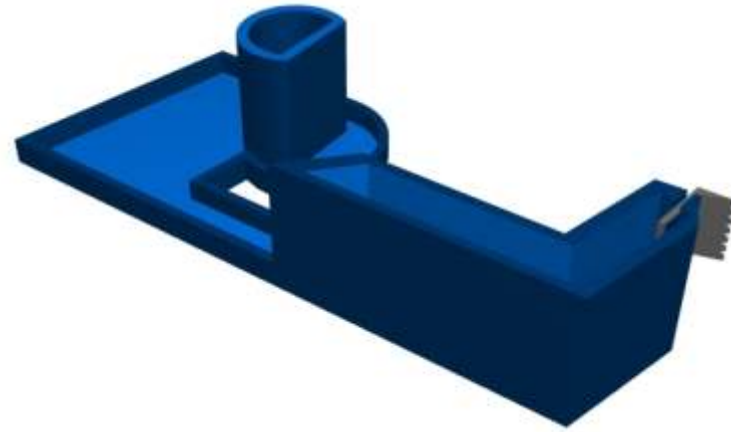

DISPENSER - BLADE MANUFACTURE

V.Ryan © 2009 World Association of Technology Teachers

5d. Describe two ways in which the cutter may be a safety hazard, especially if the dispenser is to be used by young children.

Safety Hazzard 1: _____

Safety Hazzard 2: _____

5e. In the space below redesign the cutter and/or dispenser so that it cannot be taken out of the slot. Also, ensure that hands and fingers cannot come into contact with the sharp blade.

Marks will be awarded for;

The quality of presentation of diagrams.

The quality and detail of explanatory notes and labels added to

diagrams.

NOTES

EXAMINATION QUESTION

You are to design two desk organisers. One must be made from a plastic and the other from a wood (natural or manmade). Several examples of desk organisers are shown below. Both organisers must hold / store the following equipment; glues, pens, pencils, rulers, drawing pins, paper clips, note pads, compasses and other small pieces of equipment. Storage of a mobile phone is also essential. Add notes which should include information about manufacturing processes and techniques/equipment used to manufacture each organiser.



NAME OF PLASTIC: _____

NAME OF WOOD: _____

NOTES

NOTES
