

### FINGER / COMB JOINTS

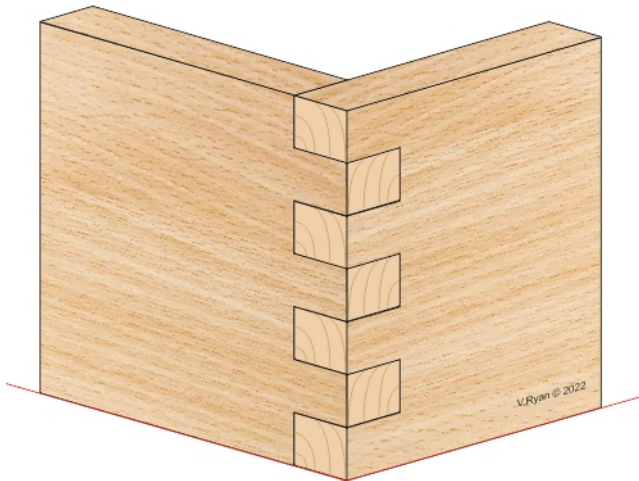

### DOVETAIL JOINTS

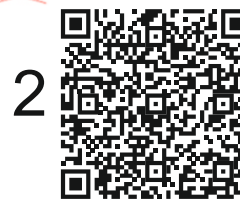
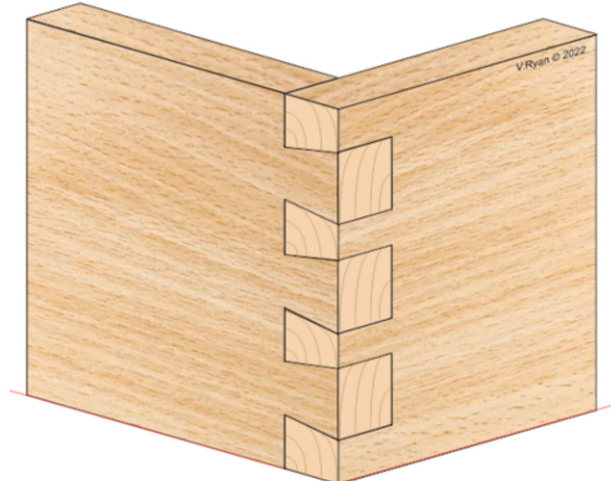

### SHOULDER / REBATE / LAPPED JOINT



### PLAIN MORTISE AND TENON

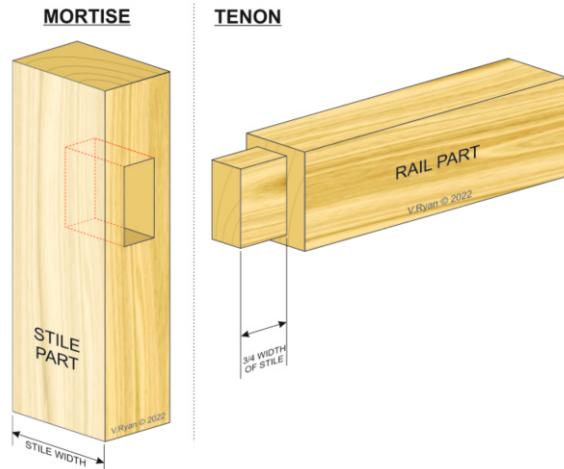

### WEDGED MORTISE AND TENON

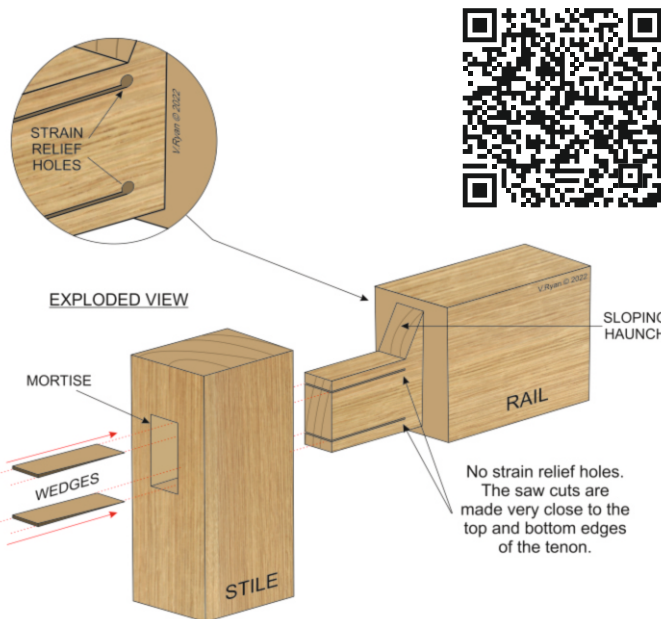

### DOWELLED MORTISE AND TENON JOINTS

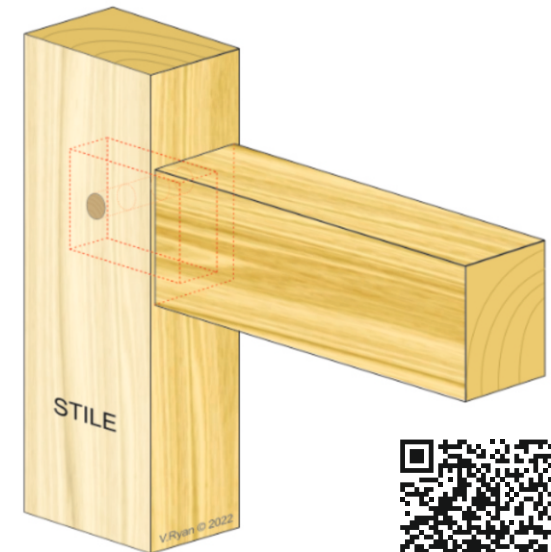

### TWIN / DOUBLE MORTISE AND TENON JOINTS

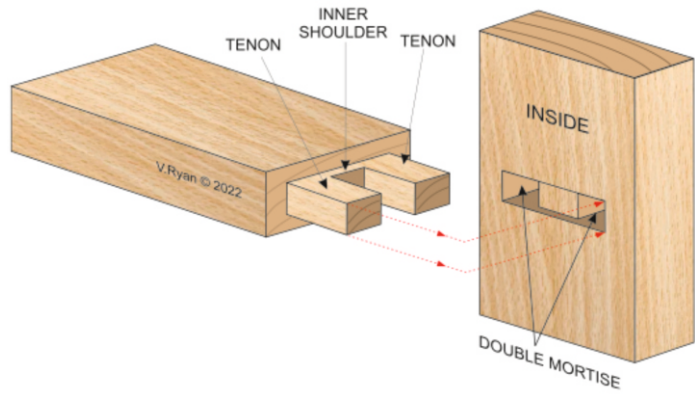

### THROUGH HOUSING JOINT

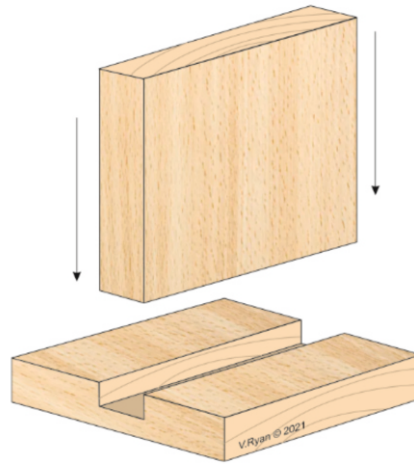

### STOPPED HOUSING JOINT

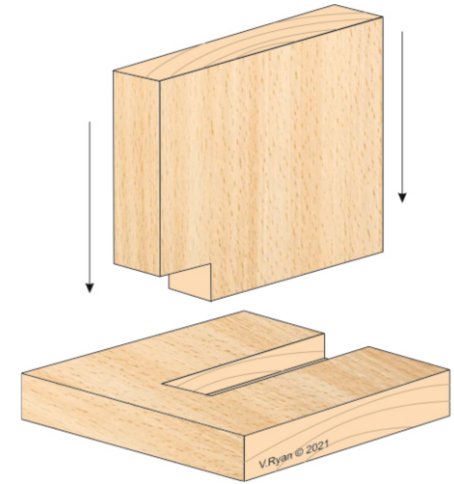

### THE BAREFACED HOUSING JOINT

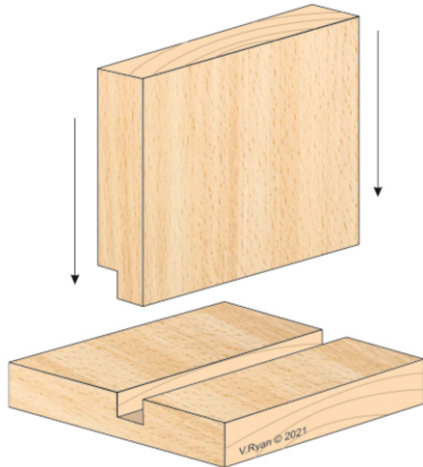

### SINGLE SIDED DOVETAIL HOUSING

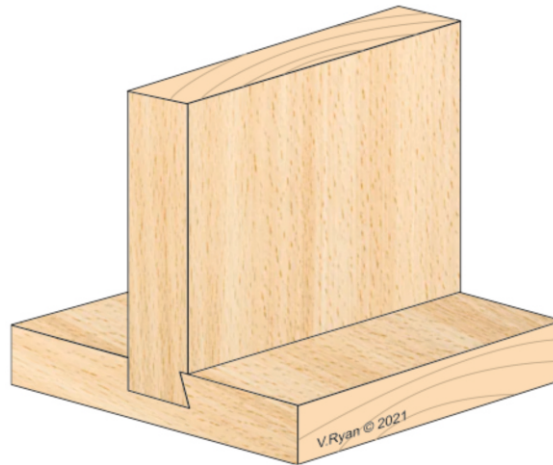

### MORE DOVETAIL HOUSING JOINTS

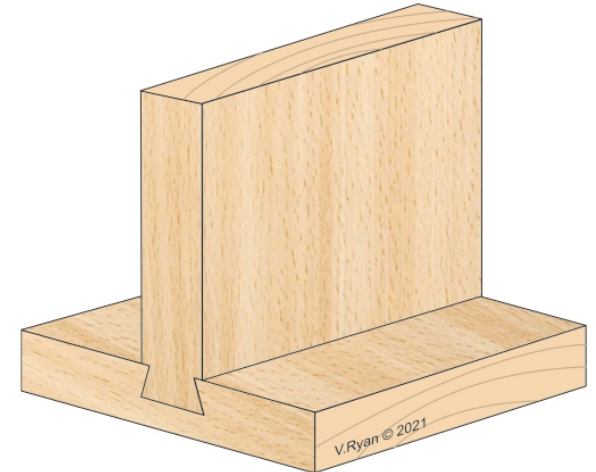

## CROSS HALVING JOINTS

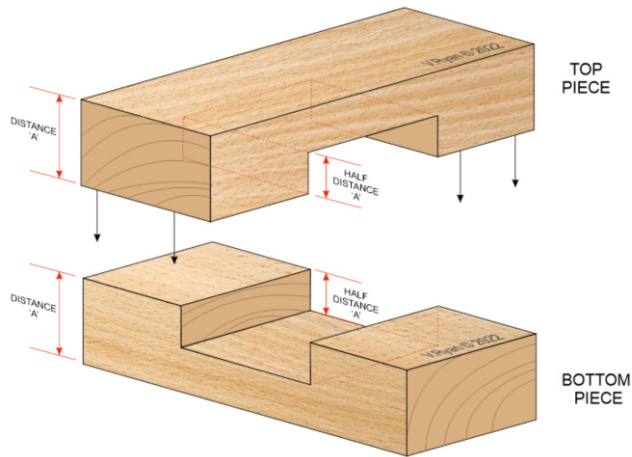

## HALF LAP

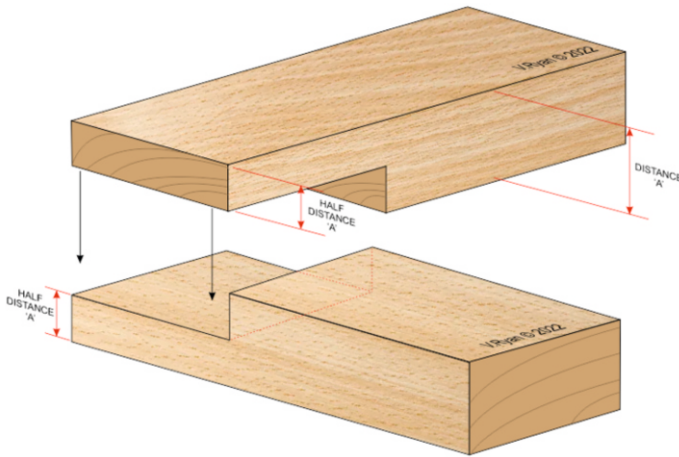

## TEE HALVING JOINT

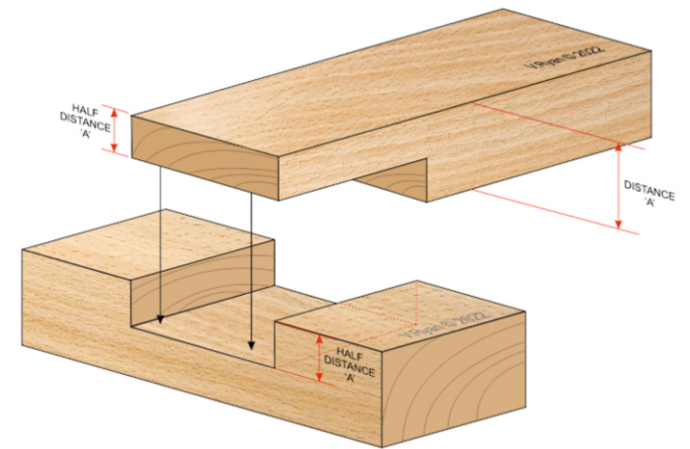

## DOVETAIL HALVING

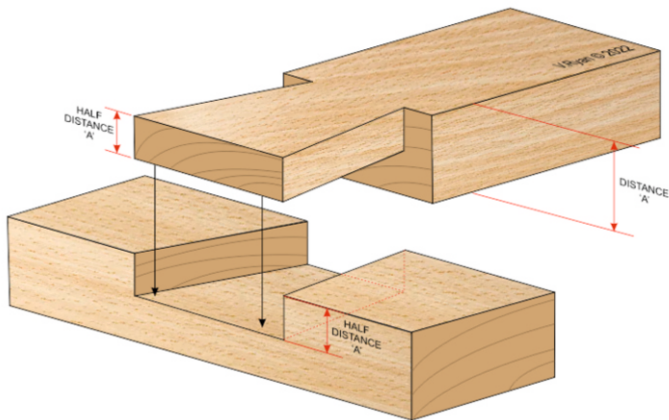

## MITRE CORNER HALVING JOINT

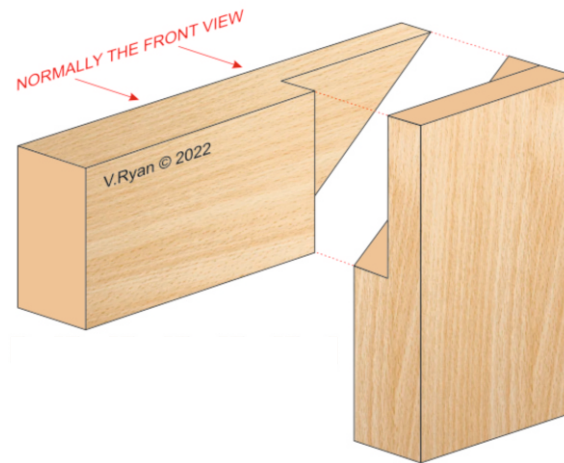

## BRIDLE JOINTS

