

WHAT IS CAD / CAM?

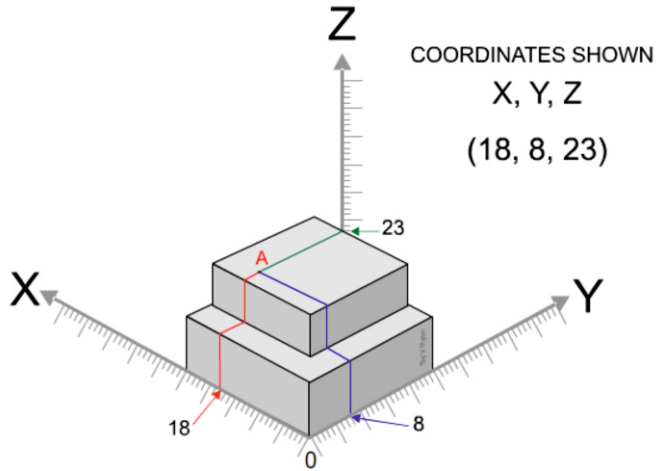

INPUT, PROCESS, OUTPUT

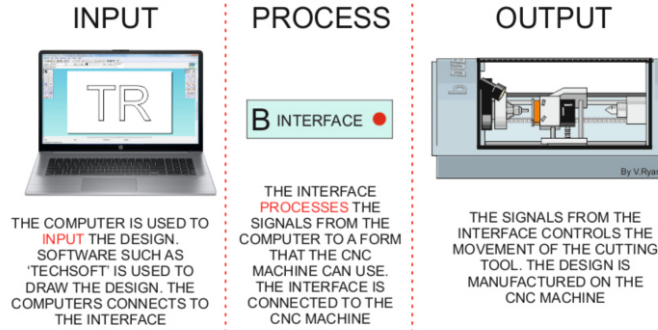

FILAMENT SPOOL 3D PRINTERS

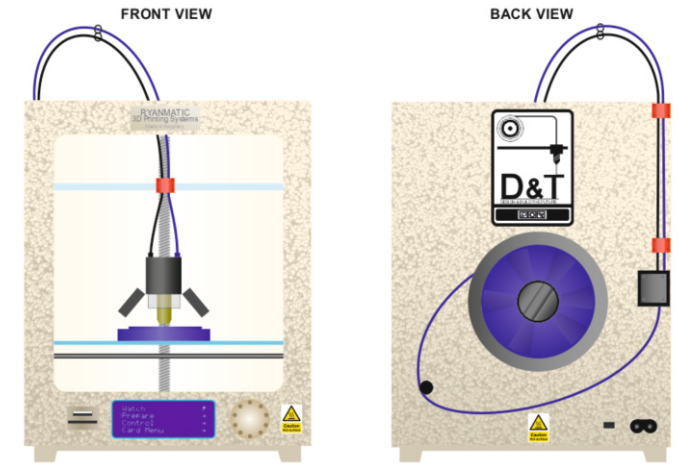

STEREOLITHOGRAPHY

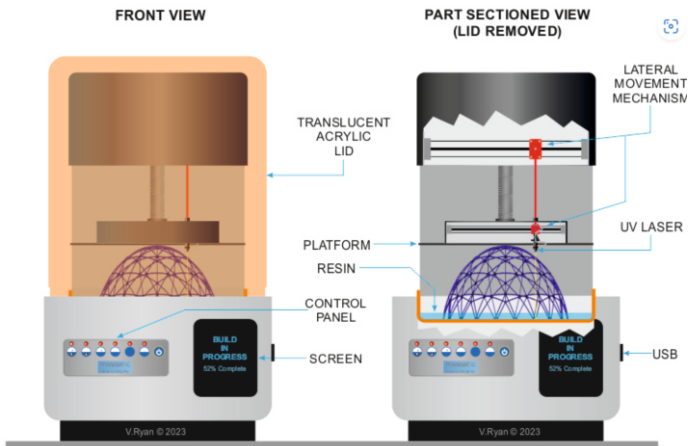

RAPID PROTOTYPING

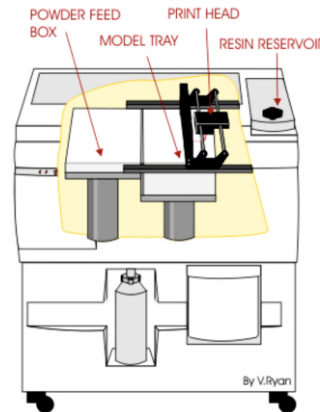

LASER CUTTING / ETCHING

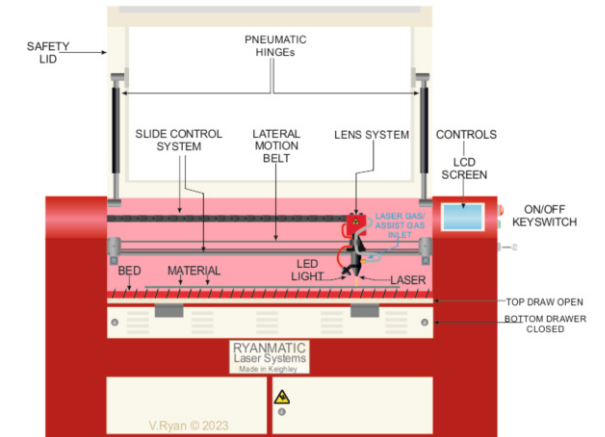

WATER JET CUTTERS

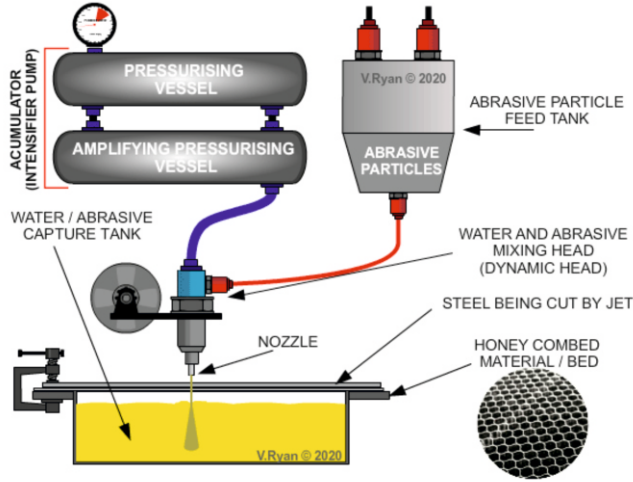

VINYL CUTTER

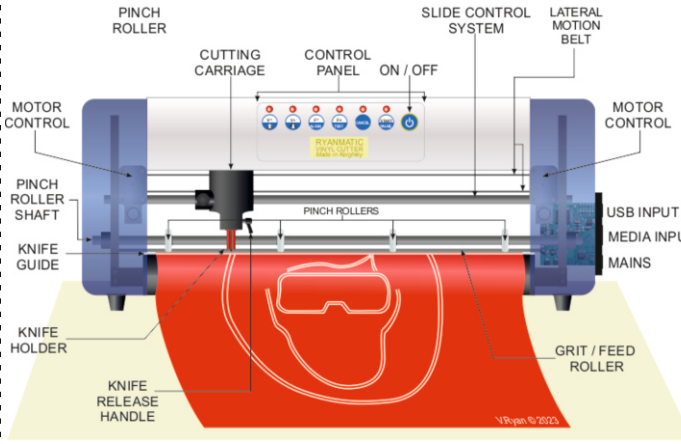

LASER SINTERING - DIRECT METAL LASER SINTERING (DMLS)

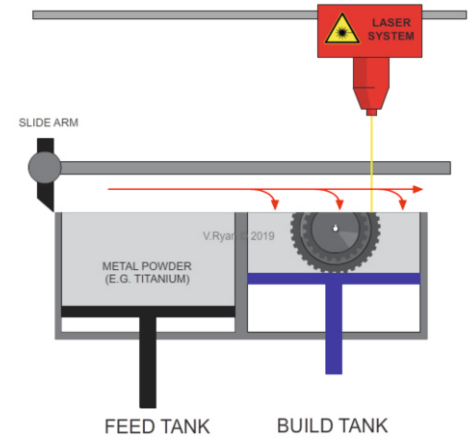

CNC TURNING CENTRE

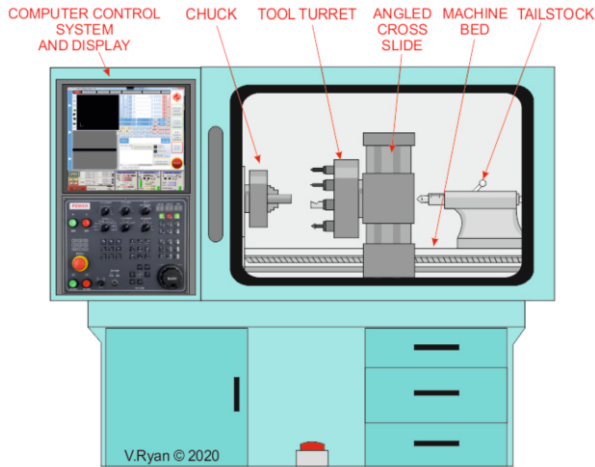

CNC METAL SPINNING

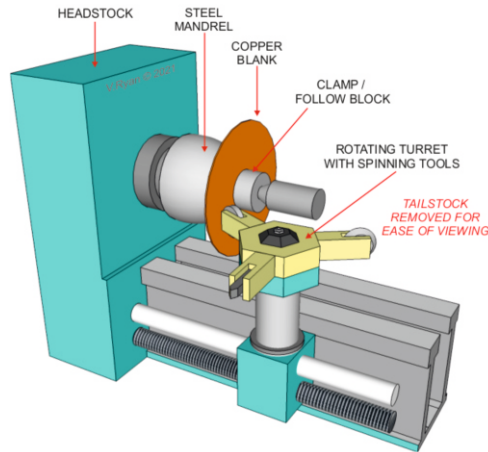

CNC ROUTER

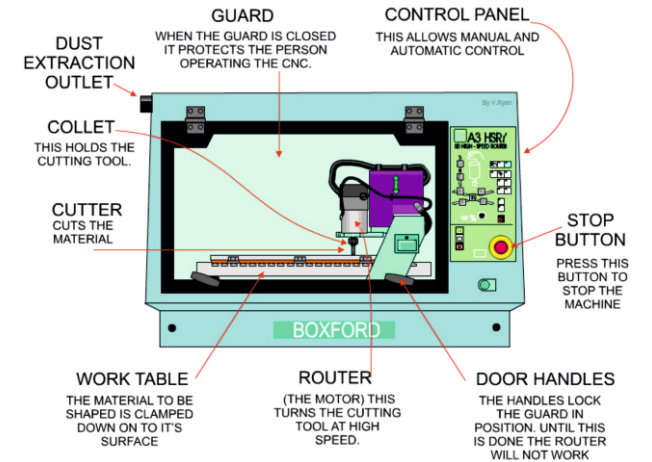

**ADVANTAGES AND DISADVANTAGES
OF CNC MACHINES**

